

Oral Fluid Drug Screen Device

Package Insert for the MET/COC/OPI/THC/BZO

Test for Oral Fluids

A rapid, screening test for the simultaneous, qualitative detection of methamphetamine, cocaine, opiates, THC, BZO and their metabolites in human oral fluid.

For Forensic Use Only

INTENDED USE

The Oral Fluid Drug Screen Device for MET/COC/OPI/THC/BZO is a lateral flow chromatographic immunoassay for the qualitative detection of methamphetamine, cocaine, opiates, THC, BZO and their metabolites in oral fluids at the following cut-off concentrations:

Test	Calibrator	Cut-off
Methamphetamine (MET)	d-Methamphetamine	50 ng/mL
Marijuana (THC)	Δ^9 - THC	50ng/mL
Benzodiazepine (BZO)	Oxazepam	10 ng/mL
Cocaine (COC)	Benzoyllecgonine	20 ng/mL
Opiates (OPI)	Morphine	40 ng/mL

This assay provides only a preliminary analytical test result. A more specific alternate chemical method must be used in order to obtain a confirmed analytical result. Gas chromatography/mass spectrometry (GC/MS) and gas chromatography/tandem mass spectrometry (GC/MS/MS) are the preferred confirmatory methods. Professional judgment should be applied to any drug of abuse test result, particularly when preliminary positive results are indicated.

SUMMARY

The Oral Fluid Drug Screen Device for MET/COC/OPI/THC/BZO and their metabolites is a rapid, oral fluid screening test that can be performed without the use of an instrument. The test utilizes monoclonal antibodies to selectively detect elevated levels of specific drugs in human oral fluid.

Methamphetamine (MET)

Methamphetamine is a potent stimulant chemically related to amphetamine but with greater CNS stimulation properties. The drug is often self-administered by nasal inhalation, smoking or oral ingestion. Depending on the route of administration, methamphetamine can be detected in oral fluid as early as 5-10 minutes following use¹. Methamphetamine can be detected in oral fluids for up to 72 hours after use¹.

The Methamphetamine assay contained within the Oral Fluid Drug Screen Device yields a positive result when the methamphetamine concentration in oral fluid exceeds 50 ng/mL.

Cocaine (COC)

Cocaine is a potent central nervous system (CNS) stimulant and a local anesthetic derived from the coca plant (erythroxylum coca). The drug is often self-administered by nasal inhalation, intravenous injection and free-base smoking. Depending on the route of administration, cocaine and metabolites benzoyllecgonine and ecgonine methyl ester can be detected in oral fluid as early as 5-10 minutes following use¹. Cocaine and benzoyllecgonine can be detected in oral fluids for up to 24 hours after use¹.

The cocaine assay contained within the Oral Fluid Drug Screen Device for cocaine and opiates yields a positive result when the cocaine metabolite in oral fluid exceeds 20 ng/mL.

Opiates (OPI)

The drug class opiates refers to any drug that is derived from the opium poppy, including naturally occurring compounds such as morphine and codeine and semi-synthetic drugs such as heroin. Opiates act to control pain by depressing the central nervous system. The drugs demonstrate addictive properties when used for sustained periods of time; symptoms of withdrawal may include sweating, shaking, nausea and irritability. Opiates can be taken orally or by injection routes including intravenous, intramuscular and subcutaneous; illegal users may also take the intravenously or by nasal inhalation. Using an immunoassay cutoff level of 40 ng/mL, codeine can be detected in the oral fluid within 1 hour following a single oral dose and can remain detectable for 7-21 hours after the dose². Heroin metabolite 6-monoacetylmorphine (6-MAM) is found more prevalently in excreted unmetabolized, and is also the major metabolic product of codeine and heroin.

The opiates assay contained within the Oral Fluid Drug Screen Device yields a positive result when the opiates concentration in oral fluid exceeds 40 ng/mL.

Marijuana (THC)

Tetrahydrocannabinol (THC), the active ingredient in the marijuana plant (*cannabis sativa*), is detectable in oral fluid shortly after use. The detection of the drug is thought to be primarily due to the direct exposure of the drug to the mouth (oral and smoking administrations) and the subsequent sequestering of the drug in the buccal cavity.³ Historical studies have shown a window of detection for THC in oral fluid of up to 14 hours after drug use.³

The THC assay contained within the Oral Fluid Drug Screen Device yields a positive result when the Δ^9 -THC concentration in oral fluid exceeds 50 ng/mL.

Benzodiazepine(BZO):

Benzodiazepines are medications that are frequently prescribed for the symptomatic treatment of anxiety and sleep disorders. They produce their effects via specific receptors involving a neurochemical called gamma aminobutyric acid (GABA). Because they are safer and more effective, Benzodiazepines have replaced Barbiturates in the treatment of both anxiety and insomnia. Benzodiazepines are also used as sedatives before some surgical and medical procedures, and for the treatment of seizure disorders and alcohol withdrawal.

ASSAY PRINCIPLE

The Oral Fluid Drug Screen Device for MET/COC/OPI/THC/BZO is an immunoassay based on the principle of competitive binding. Drugs that may be present in the oral fluid specimen compete against their respective drug conjugate for binding sites on their specific antibody.

During testing, a portion of the oral fluid specimen migrates upward by capillary action. A drug, if present in the oral fluid specimen below its cut-off concentration, will not saturate the binding sites of its specific antibody. The antibody will then react with the drug-protein conjugate and a visible colored line will show up in the test line region of the specific drug strip. The presence of drug above the cut-off concentration in the oral fluid specimen will saturate all the binding sites of the antibody. Therefore, the colored line will not form in the test line region.

A drug-positive oral fluid specimen will not generate a colored line in the specific test line region of the strip because of drug competition, while a drug-negative oral fluid specimen will generate a line in the test line region because of the absence of drug competition.

To serve as a procedural control, a colored line will always appear at the control line region, indicating that proper volume of specimen has been added and membrane wicking has occurred.

REAGENTS

The test contains membrane strips coated with drug-protein conjugates (purified bovine albumin) on the test line, a goat polyclonal antibody against gold-protein conjugate at the control line, and a dye pad which contains colloidal gold particles coated with mouse monoclonal antibody specific to Methamphetamine, Benzoyllecgonine, Morphine, THC-COOH, and BZO.

PRECAUTIONS

- For forensic use only.
- Do not use after the expiration date.
- The Oral Fluid test device should remain in the sealed pouch until use.
- Saliva is not classified as biological hazard unless derived from a dental procedure.
- The used collector and device should be discarded according to federal, state and local regulations.

STORAGE AND STABILITY

Store as packaged in the sealed pouch at 2-30°C. The test is stable through the expiration date printed on the sealed pouch. The test devices must remain in the sealed pouch until use. DO NOT FREEZE. Do not use beyond the expiration date.

SPECIMEN COLLECTION AND PREPARATION

The oral fluid specimen should be collected using the collector provided with the kit. Follow the detailed Directions for Use below. No other collection devices should be used with this assay. Oral fluid collected at any time of the day may be used.

MATERIALS

Materials Provided

- Test devices
- Collectors
- Collection chambers
- Security seals
- Package insert
- Procedure Card

Materials Required but Not Provided

- Timer

DIRECTIONS FOR USE

Allow the test device, specimen, and/or controls to reach room temperature (15-30°C) prior to testing. Instruct the donor to not place anything in the mouth including food, drink, gum or tobacco products for at least 10 minutes prior to collection.

- Specimen Collection
- Using the provided oral fluid swab, sweep the inside of the mouth for 3 minutes. The sponge will gradually soften as oral fluid is absorbed, and should be completely soft after 3 minutes.
- Stop sweeping the mouth, and push the moistened swab firmly into the specimen dispenser. Push the collector into the collection chamber and press down firmly to release as much liquid as possible. Be sure that at least 0.5 mL liquid has been collected in order to make re-confirmation test possible, if necessary.
- Tightly shut the outer cap of the specimen dispenser.
- Test Procedure
- Remove the test from its sealed pouch, and place it on a clean, level surface. Label the test with patient or control identification. For best results, the assay should be performed within one hour.
- Unscrew the dispensing tip (not the outer cap) of the specimen dispenser, and transfer 3 drops of fluid (approximately 100 μ L) to each specimen well (S) of the device and start the timer.

- Avoid trapping air bubbles in the specimen wells (S), and do not add any solution to the result areas.
- As the test begins to work, color will migrate across the membrane.
- Wait for the colored band(s) to appear. The result should be read at 10 minutes. Do not interpret the result after 20 minutes.

Specimen Dispenser and Swab

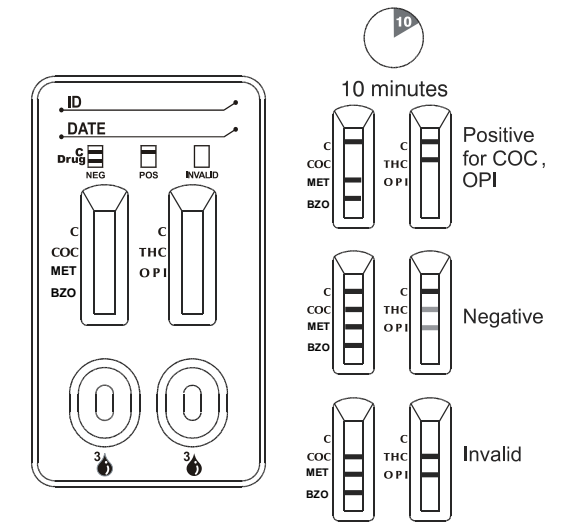
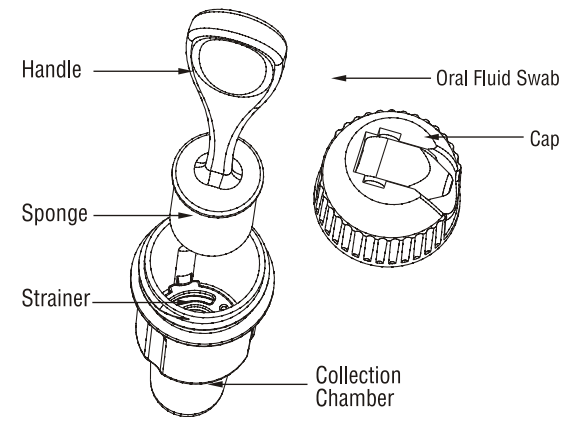

INTERPRETATION OF RESULTS

(Please refer to the previous illustration)

NEGATIVE: Two lines appear. One colored line should be in the control region (C), and another apparent colored line adjacent should be in the test region (Drug/T). This negative result indicates that the drug concentration is below the detectable level.

***NOTE:** The shade of color in the test line region (Drug/T) will vary, but it should be considered negative whenever there is even a faint line.

POSITIVE: One colored line appears in the control region (C). No line appears in the test region (Drug/T). This positive result indicates that the drug concentration is above the detectable level.

INVALID: Control line fails to appear. Insufficient specimen volume or incorrect procedural techniques are the most likely reasons for control line failure. Review the procedure and repeat the test using a new test panel. If the problem persists, discontinue using the lot immediately and contact the manufacturer.

QUALITY CONTROL

A procedural control is included in the test. A colored line appearing in the control region (C) is considered an internal procedural control. It confirms sufficient specimen volume, adequate membrane wicking and correct procedural technique.

LIMITATIONS

- The Oral Fluid Drug Screen Device provides only a qualitative, preliminary analytical result. A secondary analytical method must be used to obtain a confirmed result. Gas chromatography/mass spectrometry (GC/MS) or gas chromatography/tandem mass spectrometry (GC/MS/MS) is preferred confirmatory methods.
- A positive test result does not indicate the concentration of drug in the specimen or the route of administration.
- A negative result may not necessarily indicate a drug-free specimen. Drug may be present in the specimen below the cutoff level of the assay.

PERFORMANCE CHARACTERISTICS

Analytical Sensitivity

A Phosphate-buffered saline (PBS) pool was spiked with drugs to target concentrations of \pm 50% cut-off and \pm 25% cut-off and tested with the Oral Fluid Drug Screen Device. The results are summarized below.

Drug conc. (Cut-off range)	n	COC		MET		BZO	
		-	+	-	+	-	+
0% Cut-off	30	30	0	30	0	30	0
-50% Cut-off	30	30	0	30	0	30	0
-25% Cut-off	30	30	0	28	2	30	0
Cut-off	30	20	10	23	7	14	16
+25% Cut-off	30	6	24	7	23	4	26
+50% Cut-off	30	0	30	0	30	0	30

Drug conc. (Cut-off range)	n	THC		OPI	
		-	+	-	+
0% Cut-off	30	30	0	30	0
-50% Cut-off	30	30	0	30	0
-25% Cut-off	30	24	6	26	4
Cut-off	30	15	15	20	10
+25% Cut-off	30	11	19	5	25
+50% Cut-off	30	0	30	0	30

Analytical Specificity

The following table lists the concentration of compounds (ng/mL) above which the Oral Fluid Drug Screen device for MET/COC/OPI/THC/BZO identified positive results at a read time of 10 minutes.

Compound	ng/mL
COCAINE (COC)	
Benzoyllecgonine	20
Cocaine	20
Cocaehtylene	25
Ecgonine	1,500
Ecgonine methyl ester	12,500
METHAMPHETAMINE (MET)	
d-Methamphetamine	50
Fenfluramine	60,000
p-Hydroxymethamphetamine	400
Methoxyphenamine	25,000
3,4-Methylenedioxyamphetamine (MDMA)	50
l-Phenylephrine	4,000
Procaine	2,000
(1R,2S) - (-) Ephedrine	400
MARIJUANA (THC)	
Δ^9 -THC	50
11-nor- Δ^9 -THC-9-COOH	12
Cannabinol	3,000
Δ^8 -THC	50
Δ^9 -THC	50
OPIATES (OPI)	

Compound	ng/mL
Morphine	40
Codeine	10
Ethylmorphine	24
Hydromorphone	100
Hydrocodone	100
Levorphanol	400
Oxycodone	25,000
Morphine 3- β -D-Glucuronide	50
Norcodeine	1,500
Normorphine	12,500
Nalorphine	10,000
Oxymorphone	25,000
Thebaine	1,500
Diacetylmorphine (Heroin)	50
6-Monoacetylmorphine	25
Bilirubin	3,500
Benzodiazepine (BZO)	
Oxacepam	10
Alprazolam	15
Bromazepam	8
Chlordiazepoxide	10
Clonazepam	40
Clorazepate	20
Clbazam	6
Diazepam	15
Estazolam	10
Desalkylflurazepam	8
Flunitrazepam	10
Flurazepam	10
Lorazepam	20
Medazepam	10
Nitrazepam	10
Nordiazepam	6
Prazepam	20
Temazepam	8
Triazolam	15

Cross-Reactivity

A study was conducted to determine the cross-reactivity of the test with compounds spiked into drug-free PBS stock. The following compounds demonstrated no false positive results on the Oral Fluid Drug Screen Device when tested with at concentrations up to 100 μ g/mL.

Acetaminophen	Acetophenetidin
N-Acetylprocainamide	Acetylsalicylic acid
Aminopyrine	Amoxicillin
Ampicillin	l-Ascorbic acid
Apomorphine	Aspartame
Atropine	Benzilic acid
Benzoic acid	Benzphetamine
d/l-Brompheniramine	Caffeine
Cannabidiol	Chloral-hydrate
Chloramphenicol	Chlorothiazide
d/l-Chloropheniramine	Chlorpromazine
Chloroquine	Cholesterol
Clonidine	Cortisone
l-Cotinine	Creatinine
Deoxycorticosterone	Dextromethorphan
Diclofenac	Diflunisal
Digoxin	Diphenhydramine
l- Ψ -Ephedrine	β -Estradiol
Estrone-3-sulfate	Ethyl-p-aminobenzoate
l(-)-Epinephrine	Erythromycin
Fenoprofen	Furosemide
Gentisic acid	Hemoglobin
Hydralazine	Hydrochlorothiazide
Hydrocortisone	o-Hydroxyhippuric acid
p-Hydroxytyramine	Ibuprofen
Iproniazid	d/l-Isoproterenol
Isoxsuprine	Ketoprofen
Loperamide	Labetalol
	Meperidine

Meprobamate	Methylphenidate
Nalidixic acid	Naloxone
Naltrexone	Naproxen
Niacinamide	Nifedipine
Norethindrone	d-Norpropoxyphene
Noscapine	d/l-Octopamine
Oxalic acid	Oxolinic acid
Oxymetazoline	Papaverine
Penicillin-G	Pentazocine hydrochloride
Perphenazine	Phenelzine
Trans-2-phenylcyclopropylamine hydrochloride	Phenylpropanolamine
Prednisolone	Prednisone
d/l-Propranolol	d-Propoxyphene
d-Pseudoephedrine	Quinacrine
Quinine	Quindine
Ranitidine	Salicylic acid
Serotonin	Sulfamethazine
Sulindac	Tetracycline
Tetrahydrocortisone 3-acetate	Tetrahydrocortisone 3 (β -D-glucuronide)
Thiamine	Thioridazine
d/l-Tyrosine	Tolbutamide
Triamterene	Trifluoperazine
Trimethoprim	d/l-Tryptophan
Tyramine	Uric acid
Verapamil	Zomepirac

BIBLIOGRAPHY

- Moolchan, E., et al, "Saliva and Plasma Testing for Drugs of Abuse: Comparison of the Disposition and Pharmacological Effects of Cocaine", Addiction Research Center, IRP, NIDA, NIH, Baltimore, MD. As presented at the SOFT-TIAFT meeting October 1998.
- Kim, I, et al, "Plasma and oral fluid pharmacokinetics and pharmacodynamics after oral codeine administration", *Clin Chem*, 2002 Sept.; 48 (9), pp 1486-96.
- Schramm, W. et al, "Drugs of Abuse in Saliva: A Review," *J Anal Tox*, 1992 Jan-Feb; 16 (1), pp 1-9
- McCarron, MM, et al, "Detection of Phencyclidine Usage by Radioimmunoassay of Saliva," *J Anal Tox*, 1984 Sep-Oct.; 8 (5), pp 197-201.